

**835 - RESEALING JOINTS AND SEALING CRACKS IN
EXISTING PCCP AND HMA PAVEMENTS**

SECTION 835

**RESEALING JOINTS AND SEALING CRACKS IN
EXISTING PCCP AND HMA PAVEMENTS**

835.1 DESCRIPTION

Concrete Pavement. Re-saw the longitudinal and transverse joints, and saw or rout the random cracks in the PCCP at the locations designated in the Contract Documents or as required by the Engineer. Clean and fill the sawed or routed joints and cracks with hot type joint sealing compound.

Asphalt Pavement and Concrete Pavement with Spalled Joints and Cracks. Prepare the existing cracks and joints at the locations designated in the Contract Documents or as required by the Engineer. Fill the cracks and joints with the specified materials.

Asphalt Shoulder Adjacent to Concrete Pavement. Clean the existing longitudinal joint between PCCP and asphalt shoulder at the locations designated in the Contract Documents or as required by the Engineer. Fill the joint with hot fiber-reinforced asphalt.

BID ITEMS

Sealing PCCP Joints (Longitudinal)

Sealing PCCP Joints (Transverse)

Sealing PCCP Cracks ($>1/8"$ $<2"$)

Sealing Spalled PCCP Joints & Cracks ($>2"$ $\leq 3"$)

Sealing Spalled PCCP Joints & Cracks, Type A or B ($>2"$ $\leq 3"$)

Sealing Asphalt Cracks ($>1/8"$ $\leq 1/2"$)

Sealing Asphalt Cracks ($> 1/2"$ $<2"$)

Sealing Longitudinal Asphalt Shoulder Joint

UNITS

Linear Foot

Linear Foot

Linear Foot

Linear Foot

Linear Foot

Linear Foot

Linear Foot

Linear Foot

835.2 MATERIALS

a. Hot Type Joint Sealing Compound. When required, provide hot type joint sealing compound that complies with **DIVISION 1500**. When required, provide backer rod intended for use with the hot type joint sealing compound.

b. Fiber-Reinforced Asphalt. When required, provide a mixture of performance graded asphalt binder and polypropylene fibers. Provide a mixture that has not less than 8% fiber content by weight.

Provide PG 64-22 asphalt binder that complies with **DIVISION 1200**.

Provide polypropylene fibers suitable for the intended use that have a denier of 15 ± 3 . The Engineer will accept the polypropylene fibers based on a Type D Certification according to **DIVISION 2600**, and visual inspection of the mixture.

c. Rapid-Set Concrete Patching Material. When required, provide rapid-set concrete patching material that complies with **DIVISION 1700**. Provide foam core backer board intended for use with the rapid-set concrete patching material.

835.3 CONSTRUCTION REQUIREMENTS.

a. Concrete Pavement, Joints and Cracks.

(1) Transverse Joints. Saw the existing transverse joints with a saw blade wide enough to clean both surfaces of the cut removing the existing sealant. Configure the transverse joints according to **FIGURE 835-1**.

**835 - RESEALING JOINTS AND SEALING CRACKS IN
EXISTING PCCP AND HMA PAVEMENTS**

FIGURE 835-1: PCCP SAWED TRANSVERSE JOINT DETAIL

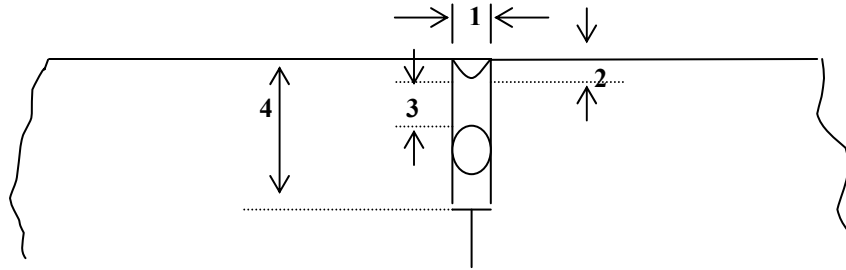

TABLE 835-1: PCCP SAWED JOINT DIMENSIONS*

1 Joint Width	2 Recess Below Surface	3 Sealant Thickness	Backer Rod Diameter	4 Total Joint Depth
1/4"	1/8" to 1/4"	3/8"	3/8"	1"
3/8"	1/8" to 1/4"	3/8"	1/2"	1 1/8"
1/2"	1/8" to 1/4"	3/8"	5/8"	1 1/4"
5/8"	1/8" to 1/4"	1/2"	3/4"	1 1/2"
3/4"	1/8" to 1/4"	1/2"	7/8"	1 5/8"
7/8"	1/8" to 1/4"	1/2"	1"	1 3/4"
1"	1/8" to 1/4"	1/2"	1 1/8"	1 7/8"
1 1/2"	1/8" to 1/4"	3/4"	1 3/4"	2 3/8"
2"	1/8" to 1/4"	1"	2 1/2"	3 5/8"

*All dimensions are nominal.

Clean, and fill the transverse joints according to **subsections 502.3g.(8) and (9)**.

(2) Longitudinal Joints. Saw the existing longitudinal joints with a saw blade 1/8" to 1/4" wider than the joint, cleaning both surfaces of the cut, and, removing all existing sealant. Configure the longitudinal joints to the width in column 1 in **TABLE 835-1**, with the depth equal to the original depth of the longitudinal joint. Clean and fill the longitudinal joints according to **subsections 502.3g.(8) and (9)**. Fill the longitudinal joint with hot type joint sealant compound to within 1/8 to 1/4 inch of the surface. Do not use backer rods in the longitudinal joints.

(3) Random Cracks. Rout or saw random cracks greater than 1/8 inch wide with a blade 1/8 to 1/4 inch wider than the crack and to a depth equal to the full width of the blade to produce a cut on each side of the crack for the full length of the crack. Clean, and fill the random cracks according to **subsections 502.3g.(8) and (9)**. Fill the random cracks (routed or sawed reservoir) with a hot type joint sealing compound to within 1/8 to 1/4 inch of the surface. Do not use backer rods in the random cracks.

b. Concrete Pavement, Spalled Joints and Cracks. Clean the full depth of the spalled joints and cracks. Remove all foreign material that will prevent bonding of the sealant. Clean the joints and cracks by sandblasting. Remove loose material on the surface immediately adjacent to the joints and cracks.

Do not seal PCCP spalled joints or cracks greater than 3 inches wide.

If the PCCP joints and cracks are 3 inches or less wide and 1 5/8 inches or less deep, fill the joints and cracks with hot fiber-reinforced asphalt. See **FIGURE 835-2**. Fill the joints and cracks to a level slightly recessed from the pavement surface.

**835 - RESEALING JOINTS AND SEALING CRACKS IN
EXISTING PCCP AND HMA PAVEMENTS**

**FIGURE 835-2: SEALING PCCP, SPALLED JOINTS AND CRACKS
($>2" \leq 3"$ wide, $\leq 1\frac{5}{8}"$ deep)**

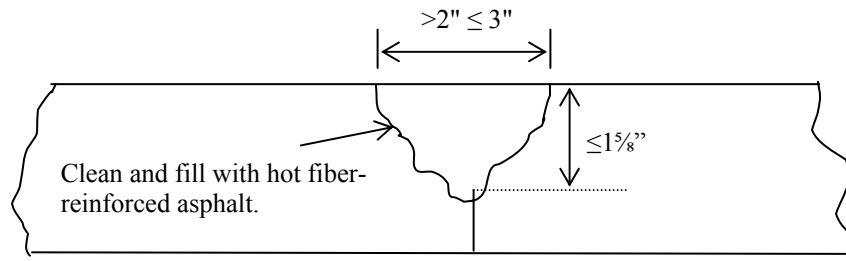

If the PCCP joints and cracks are 3 inches, or less, wide and greater than $1\frac{5}{8}$ inches deep, use either the Type A option (FIGURE 835-3) or the Type B option (FIGURE 835-4) to fill the joints and cracks:

**FIGURE 835-3: TYPE A, SEALING PCCP, SPALLED JOINTS AND CRACKS
($>2" \leq 3"$ wide, $>1\frac{5}{8}"$ deep)**

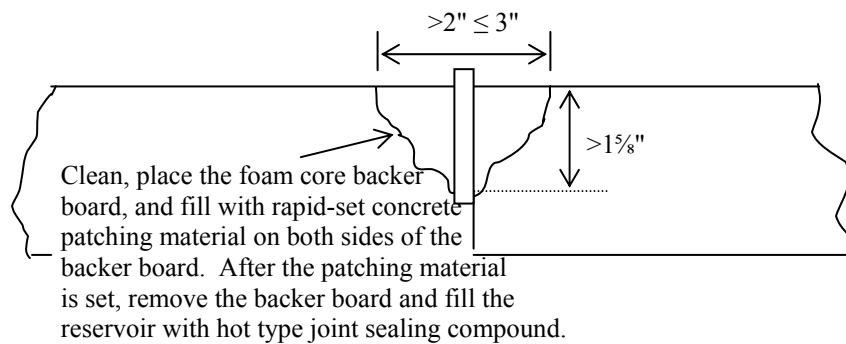

**FIGURE 835-4: TYPE B, SEALING PCCP, SPALLED JOINTS AND CRACKS
($>2" \leq 3"$ wide, $>1\frac{5}{8}"$ deep)**

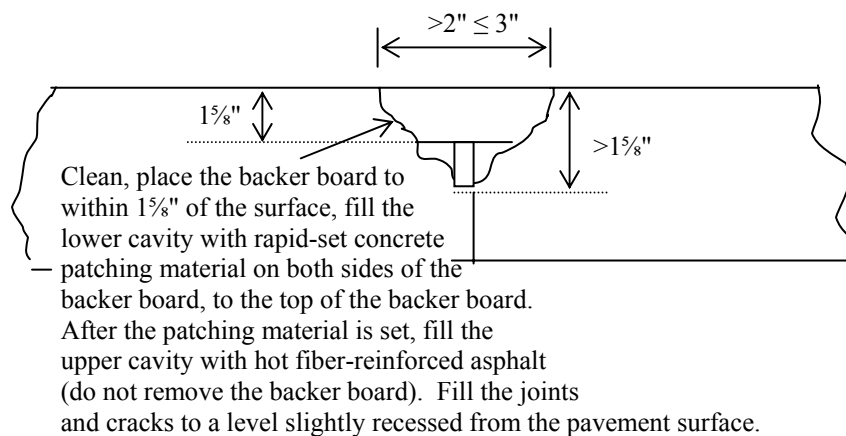

c. Asphalt Pavement Cracks. Seal cracks in asphalt pavement that are equal to or greater than $\frac{1}{8}$ inch wide. Do not seal cracks less than $\frac{1}{8}$ inch wide. Do not seal cracks wider than 2 inches. See FIGURE 835-5.

835 - RESEALING JOINTS AND SEALING CRACKS IN EXISTING PCCP AND HMA PAVEMENTS

Rout all the cracks that are $\frac{1}{8}$ to $\frac{1}{2}$ inch wide following the existing crack. Route cracks $\frac{1}{8}$ to $\frac{3}{8}$ inch with a $\frac{5}{8}$ inch router head, $\frac{3}{8}$ to $\frac{1}{2}$ inch with a $\frac{3}{4}$ inch router head and to a depth equal to or greater than the router head width. Cracks wider than $\frac{1}{2}$ inch do not require routing.

Clean the full depth of the cracks. Remove all foreign material that will prevent bonding of the sealant. Remove loose material on the surface immediately adjacent to the joints and cracks. Clean and dry the cracks with a heat lance. Do not burn the pavement (indicated by smoke) with the heat lance.

Fill the routed cracks ($\frac{1}{8}$ to $\frac{1}{2}$ inch) with hot type joint sealing compound. Fill un-routed cracks wider than $\frac{1}{2}$ inch with hot fiber-reinforced asphalt. Fill all cracks to a level slightly recessed from the pavement surface.

FIGURE 835-5: SEALING ASPHALT PAVEMENT CRACKS) ($>\frac{1}{8}$ " <2 ")

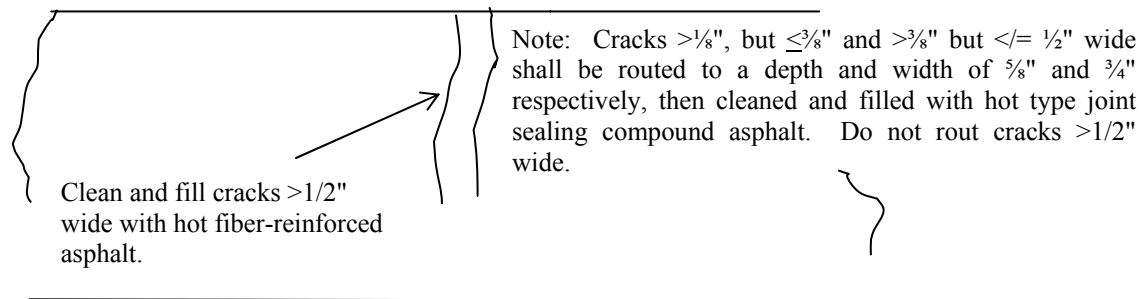

d. Asphalt Shoulder Adjacent to Concrete Pavement. Saw the concrete pavement to asphalt shoulder joint a minimum of $\frac{1}{2}$ inch by 1 inch or $\frac{1}{8}$ inch greater than the width of the existing crack 1 inch deep. Clean the joints as required in **subsection 502.3g.(8)**. Fill the joint with hot fiber-reinforced asphalt. Fill the joint with sealant to within $\frac{1}{8}$ to $\frac{1}{4}$ inch of the surface. Do not use backer rods in the joints.

e. Manufacturer's Representative. Notify the sealant manufacturer's technical representative of the starting date of the initial installation. Demonstrate competence in applying sealant to the Engineer and the manufacturer's representative. Do not perform operations or procedures that would be detrimental to the sealing of joints and cracks.

This requirement will be waived for experienced Contractor's crews. Submit waiver request, along with a list of joint sealant crews successfully completed joint and crack sealing projects, to the Engineer for consideration.

f. Preparation of Asphalt for Crack Sealing. Heat the material to the temperature recommended by the manufacturer.

g. Weather Limitations. Do not place sealant when the ambient air temperature is below 40°F or above 85°F.

835.4 MEASUREMENT AND PAYMENT

The Engineer will measure sealing of joints and random cracks by the linear foot along the center of the joint or crack.

Payment for "Sealing PCCP Joints (Longitudinal)", "Sealing PCCP Joints (Transverse)", "Sealing PCCP Cracks ($>\frac{1}{8}$ " <2 "")", "Sealing Spalled PCCP Joints & Cracks (>2 " ≤ 3 "")", "Sealing Spalled PCCP Joints & Cracks, Type A or B (>2 " ≤ 3 "")", "Sealing Asphalt Cracks ($>\frac{1}{8}$ " $\leq \frac{1}{2}$ "")", "Sealing Asphalt Cracks ($> \frac{1}{2}$ " <2 "")" and "Sealing Longitudinal Asphalt Shoulder Joint" at the contract unit prices is full compensation for the specified work.